



# BE-870LM vehicle CCTV monitor

Quick installation guide

Guide d'installation rapide

Kurzanleitung

Guida di installazione rapida

Guía rápida de instalación

Snelle installatie handleiding

Guia rápida de instalação

Руководство по быстрой установке

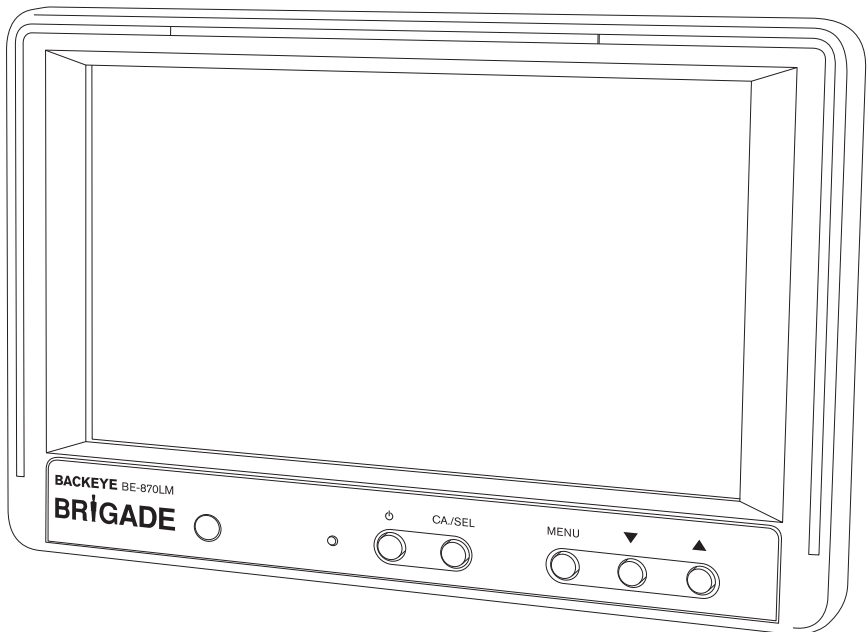

# 1 Contents

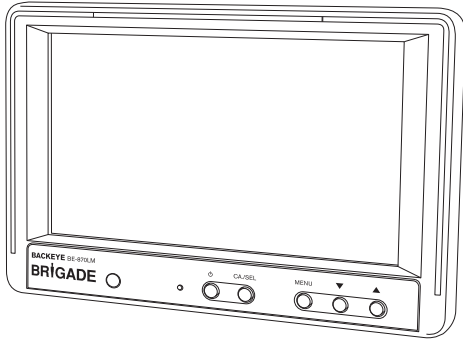

BE-870LM-M

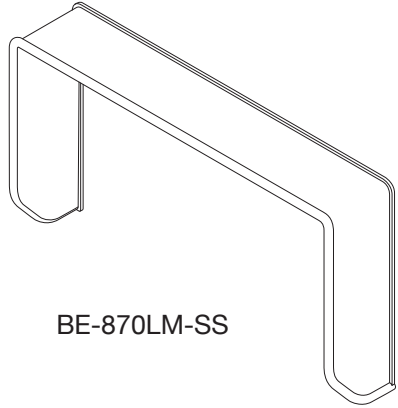

BE-870LM-SS

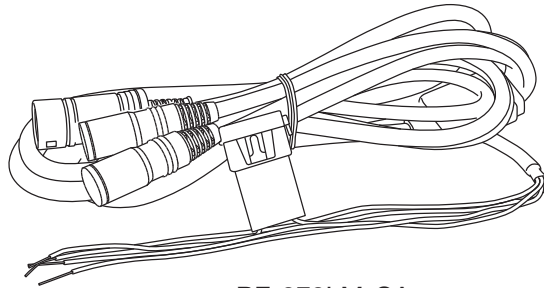

BE-870LM-CA

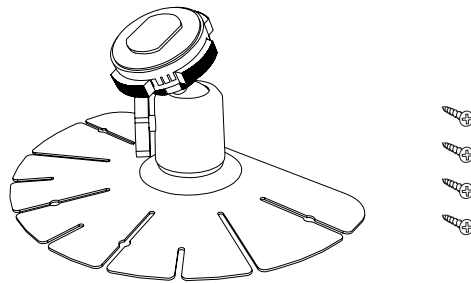

BMM-022

## 2 Monitor installation

Surveiller l'installation/Monitor-Einbau/L'installazione del monitor/  
Instalación del monitor/Monitor installatie/ Instalação do monitor/

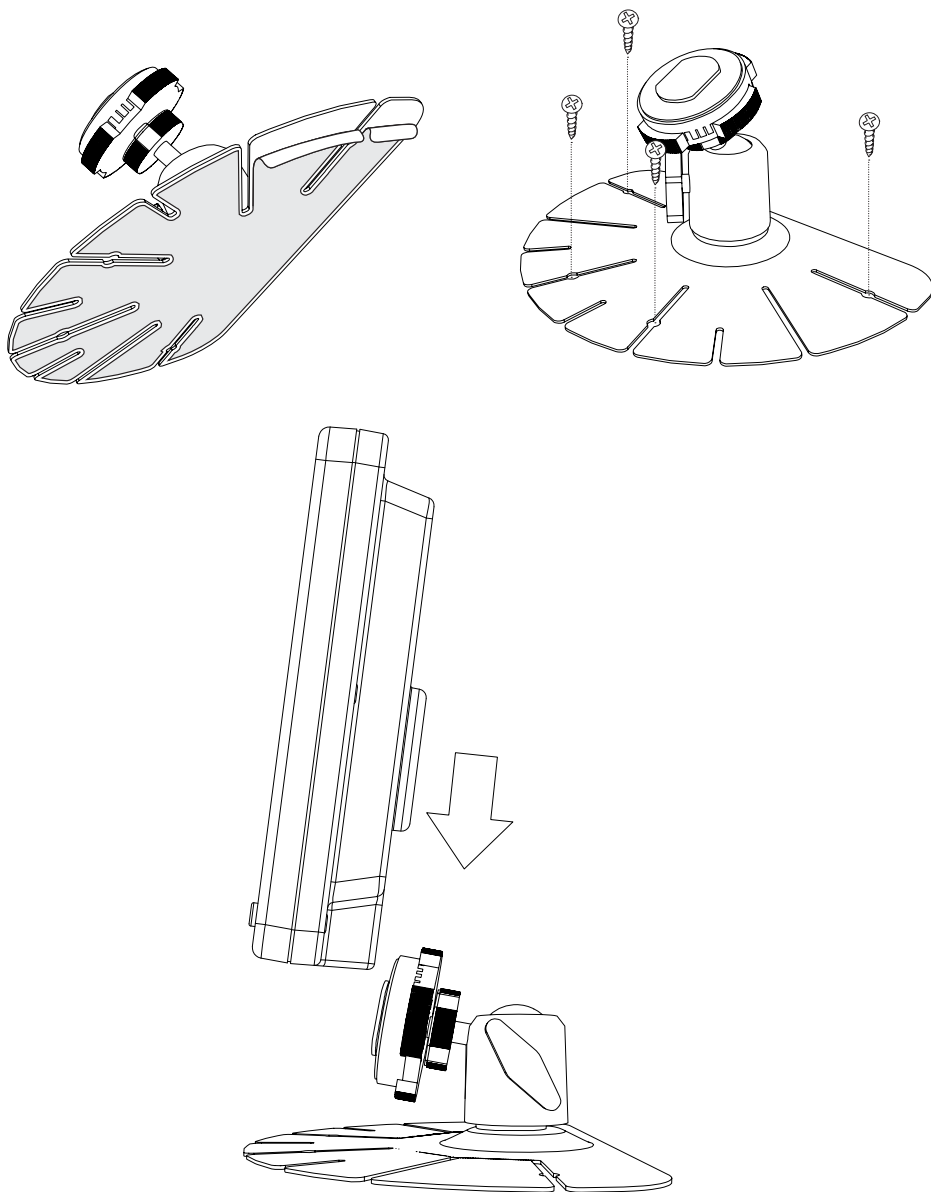

# 3 Connections

Connexions/Anschlüsse/Conessioni/Conexiones/Aansluitingen/Conexão/  
Сигнал скорости

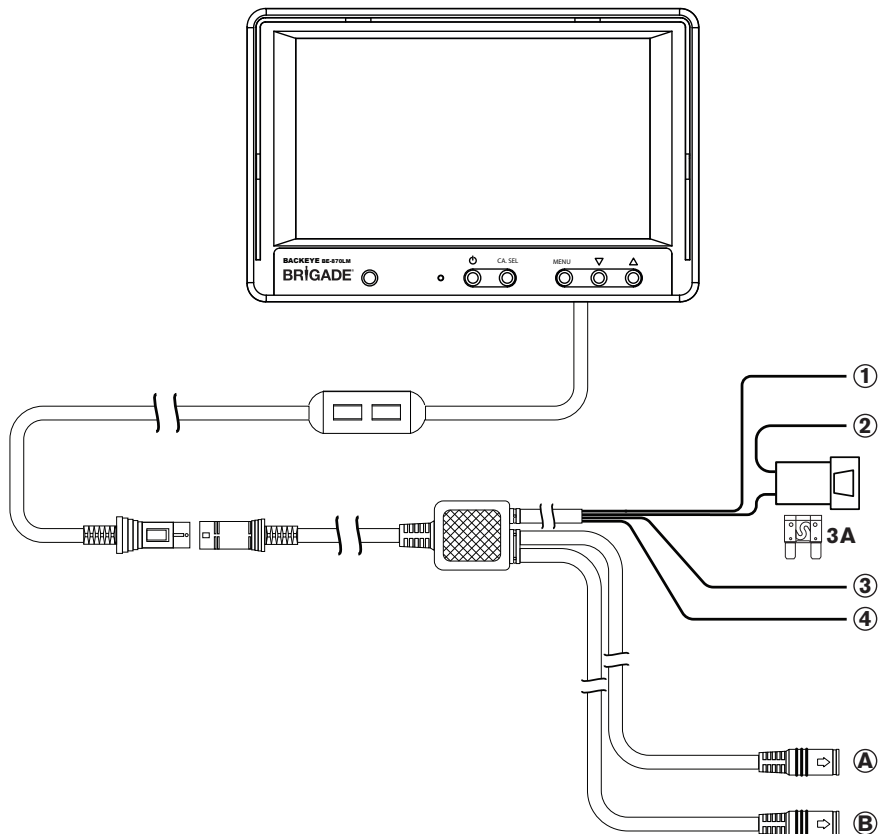

Black	Ground	Red	Power
Noir	Masse	Rouge	Positif
Schwarz	Masse	Rot	Betriebsspannung
Nero	Massa	Rosso	Positivo
Negro	Masa	Rojo	Positivo
Zwart	Grond	Rood	Vermogen
Preto	Massa	Vermelho	Positivo
черный	заземление	красный	мощность

Trigger	Green	White		
Déclencher	Vert	Blanc		
Trigger	Grün	Weiß		
Attivare	Verde	Bianco		
Desencadenar	Verde	CA1	Blanco	CA2
Trekker	Groen	Wit		
Gatilho	Verde	Branco		
триггер	зеленый	белый		

Camera	
Caméra	
Kamera	
Telecamera	A B
Cámara	CA1 CA2
Camera	
Câmera	
камера	

# 4 Controls

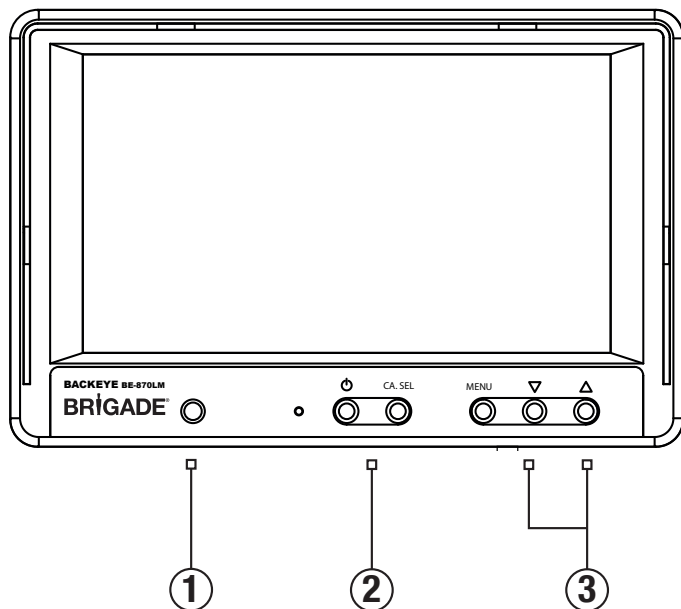

- ① Automatic low light sensor.  
Capteur optique automatique de basse luminosité.  
Licht Sensor.  
Sensore automatico di bassa luminosità.  
Sensor automático de baja luminosidad.  
Automatische lage lichtsensor.  
Sensor de luz baixa automática.  
Автоматический датчик низкой освещенности.

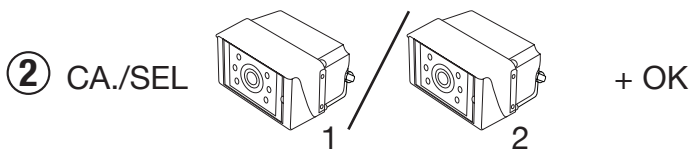

# 5 Operation

Opération/Betrieb/Operazione/Operación/Werking/Operação/операция

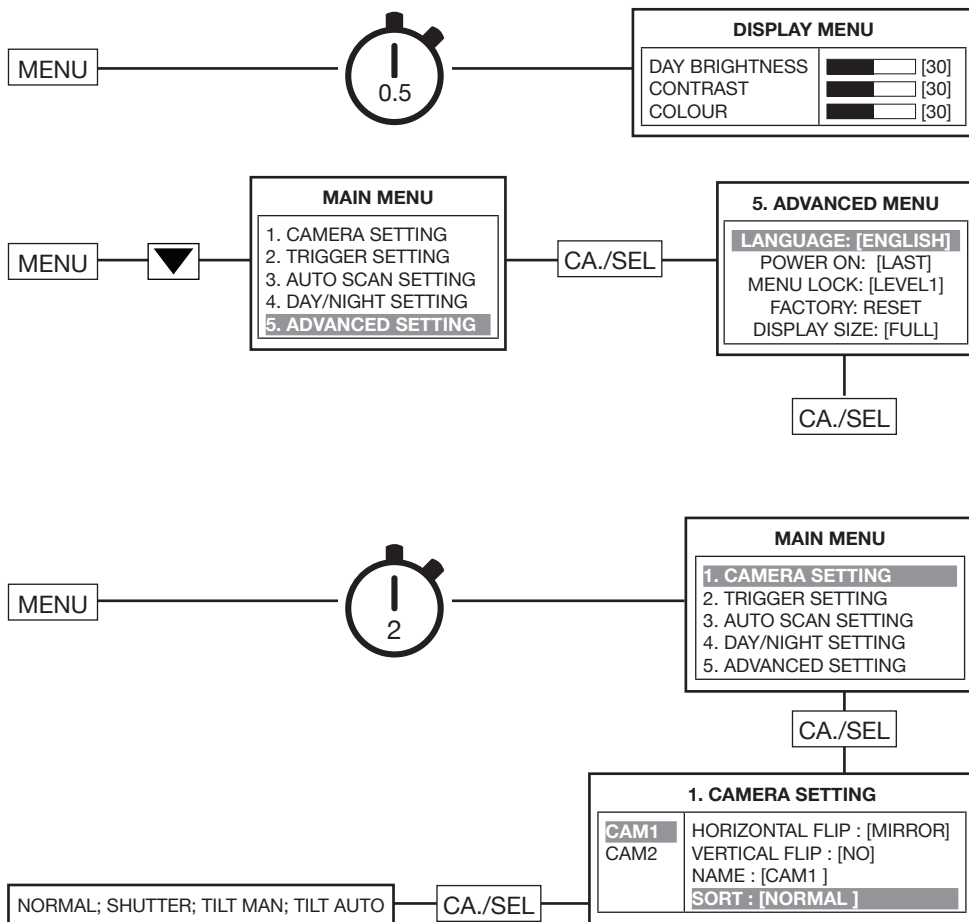

## Trigger setting

Paramètre de déclenchement/Trigger-Einstellung/Impostazione trigger/  
Configuración de disparadores/Drempelwaarde/Configuração de acionadores/  
настройки пускового

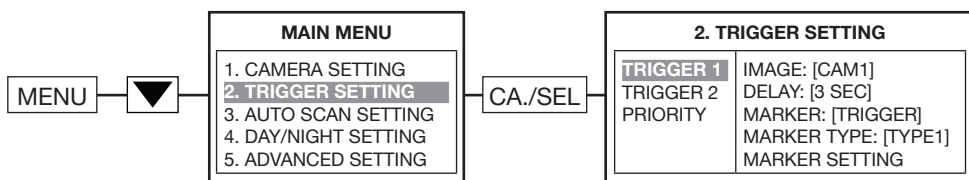

# 5 Operation

Opération/Betrieb/Operazione/Operación/Werking/Operação/операция

## BUTTON LOCK

Bouton de verrouillage/Tastensperre/Pulsante di blocco/Botón de bloqueo/

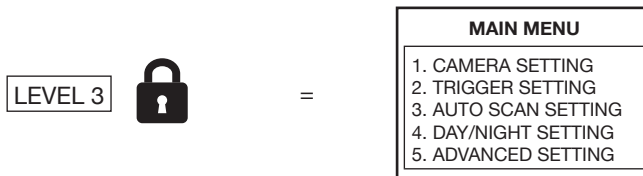
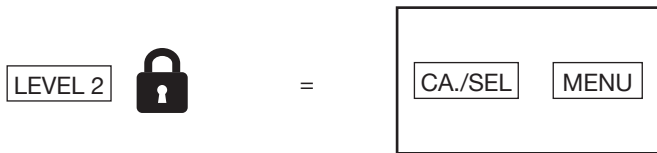
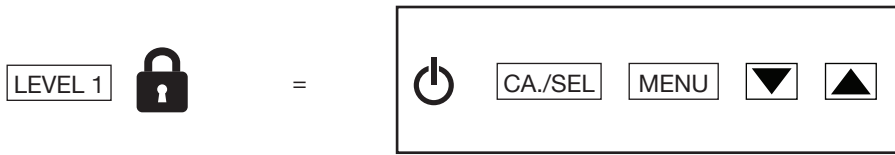
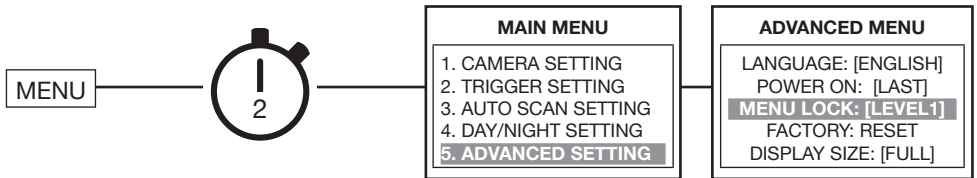
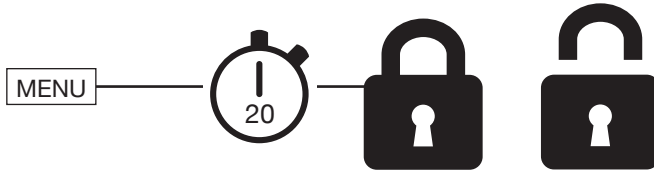

# 5 Operation

Opération/Betrieb/Operazione/Operación/Werking/Operação/операция

## MARKER SETTING

Mise en marqueur/Einstellung der Markierungen/Impostazione dei marcatori/  
Ajuste de los marcadores/Marker instelling/Definir os marcadores/установкой бита

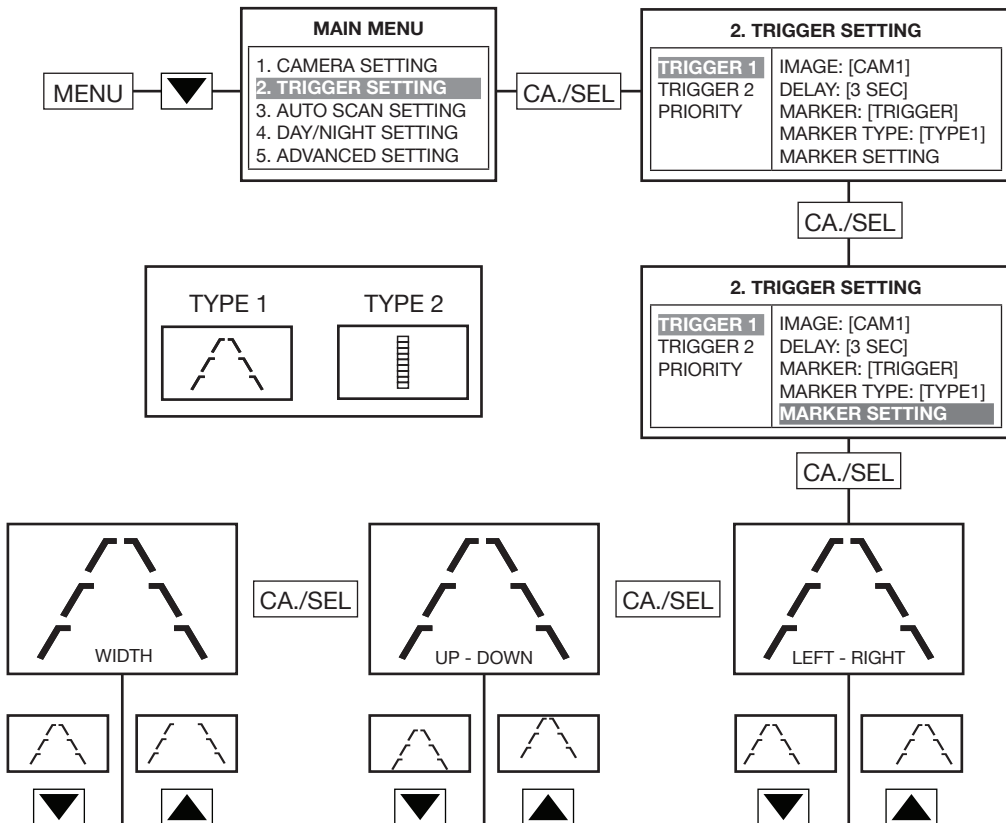

# 6 Specifications

Spécifications/Spesifikationer/Specifiche/Especificaciones/Specificaties/

ENGLISH	
<b>Specifications</b>	
Monitor	BE-870LM
TV system	NTSC/PAL
Picture	7" TFT LCD colour monitor with on-screen display function
Display size	7" diagonal
Field of view	Top: 50°, Bottom: 70°, Left: 70°, Right: 70°
Resolution	(800x3(RGB)x480)
Picture image	Factory set to reverse image
Power	12/24Vdc input
Inputs	2 x camera
Dimensions	197(w) x 128(h) x 33.5(d)mm 7.8(w) x 4.9(h) x 1.3(d) inches
Operating temperature	-30°C ~ +70°C -22°F ~ +158°F

FRANÇAIS	
<b>Specifications</b>	
Moniteur	BE-870LM
Système TV	NTSC/PAL
Image	7" TFT LCD moniteur couleur avec affichage de fonction (OSD)
Dimension de l'écran	7" diagonal
Champ de vision	Haut: 50°, Bas: 70°, Gauche: 70°, Droite: 70°
Résolution	(800x3(RGB)x480)
Image vidéo	Réglage d'usine sur image inverse
Alimentation	12/24Vdc input
Entrées	2 x caméra
Dimensions	197(w) x 128(h) x 33,5(d)mm 7,8(w) x 4,9(h) x 1,3(d) inches
Température d'utilisation	-30°C ~ +70°C -22°F ~ +158°F

ITALIANO	
<b>Specifiche</b>	
Schermo	BE-870LM
Sistema TV	NTSC/PAL
Immagine	7" TFT LCD colour monitor with on-screen display function
Formato display	7" diagonale
Campo visivo	Top: 50°, Bottom: 70°, Left: 70°, Right: 70°
Risoluzione	(800x3(RGB)x480)
Immagine a video	Immagine reversibile programmabile
Alimentazione	12/24Vdc input
Prese	2 x telecamera
Dimensioni	197(w) x 128(h) x 33.5(d)mm 7.8(w) x 4.9(h) x 1.3(d) inches
Temperatura di servizio	-30°C ~ +70°C -22°F ~ +158°F

DEUTSCH	
<b>Spezifikationen</b>	
Monitor	BE-870LM
TV-System	NTSC/PAL
Bild	7" TFT LCD Farbmonitor mit Funktionsanzeige (OSD)
Bildschirmgröße	7" diagonal
Sichtfeld	Oben: 50°, Unten: 70°, Links: 70°, Rechts: 70°
Auflösung	(800x3(RGB)x480)
Videobild	Werkseinstellung Reversebild
Stromversorgung	12/24Vdc input
Eingänge	2 x Kamera
Abmessungen	197(w) x 128(h) x 33.5(d)mm 7.8(w) x 4.9(h) x 1.3(d) inches
Betriebstemperatur	-30°C ~ +70°C -22°F ~ +158°F

# 6 Specifications

Spécifications/Spesifikationen/Specifiche/Especificaciones/Specificaties/  
Especificações/Спецификация

ESPAÑOL	
<b>Especificaciones</b>	
Monitor	BE-870LM
Sistema de TV	NTSC/PAL
Imagen	Monitor a color de 7" TFT LCD con visualización de las funciones (OSD)
Tamaño de pantalla	7" diagonal
Campo visual	arriba: 50°, abajo: 70°, a la izquierda: 70°, a la derecha: 70°
Resolución	(800x3(RGB)x480)
Imagen de vídeo	Ajuste de fábrica de la imagen inversa
Suministro de corriente	12/24Vdc entrada
Entradas	2 x cámara
Dimensiones	197(w) x 128(h) x 33.5(d)mm 7.8(w) x 4.9(h) x 1.3(d) inches
Temperatura de servicio	-30°C ~ +70°C -22°F ~ +158°F

PORTUGUÊS	
<b>Especificaciones</b>	
Monitor	BE-870LM
Sistema de TV	NTSC/PAL
Imagen	Monitor a color de 7" TFT LCD con visualización de las funciones (OSD)
Tamaño de pantalla	7" diagonal
Campo visual	arriba: 50°, abajo: 70°, a la izquierda: 70°, a la derecha: 70°
Resolución	(800x3(RGB)x480)
Imagen de vídeo	Ajuste de fábrica de la imagen inversa
Suministro de corriente	12/24Vdc entrada
Entradas	2 x cámara
Dimensiones	197(w) x 128(h) x 33.5(d)mm 7.8(w) x 4.9(h) x 1.3(d) inches
Temperatura de servicio	-30°C ~ +70°C -22°F ~ +158°F

NEDERLANDS	
<b>Specificaties</b>	
Monitor	BE-870LM
TV-systeem	NTSC/PAL
Beeld	7" TFT LCD colour monitor with on-screen display function
Displayformaat	7" diagonaal
Gezichtsveld	Boven: 50°, Onder: 70°, Links: 70°, Rechts: 70°
Resolutie	(800x3(RGB)x480)
Videobeeld	Fabrieksinstelling reversebeeld
Stroomvoorziening	12/24Vdc Ingang
Ingangen	2 x camera
Afmetingen	197(w) x 128(h) x 33.5(d)mm 7.8(w) x 4.9(h) x 1.3(d) inches
Bedrijfstemperatuur	-30°C ~ +70°C -22°F ~ +158°F

Русский	
<b>Спецификация</b>	
монитор	BE-870LM
ТВ-система	NTSC/PAL
изображение	7 "TFT LCD цветной монитор с функцией индикации на экране
размер дисплея	7" диагональ
Угол обзора	топ: 50°, дно: 70°, слева: 70°, право: 70°
Разрешение	(800x3(RGB)x480)
фото изображение	заводская настройка обратного изображения
Напряжение	12/24Vdc затраты
затраты	2 x камеры
размеры	197(ш) x 128(в) x 33.5(г)mm 7.8(ш) x 4.9(в) x 1.3(г) дюймов
Рабочая температура	-30°C ~ +70°C -22°F ~ +158°F

### **Disclaimer**

Camera monitor systems are an invaluable driver aid but do not exempt the driver from taking every normal precaution when conducting a manoeuvre. No liability arising out of the use or failure of the product can in any way be attached to Brigade or to the distributor.

### **Dénégation**

Les systèmes de moniteurs des caméras sont une aide précieuse pour le conducteur, mais celui-ci doit toutefois prendre toutes les précautions nécessaires pendant les manœuvres. Brigade ou ses distributeurs n'assument aucune responsabilité résultant de l'utilisation ou d'un défaut du produit.

### **Haftungsausschluss**

Kamera-Monitor-Systeme sind für den Fahrer eine unschätzbare Hilfe, ersetzen aber beim Manövrieren keinesfalls die üblichen Vorsichtsmaßnahmen. Für Schäden aufgrund der Verwendung oder eines Defekts dieses Produkts übernehmen Brigade oder der Vertriebshändler keinerlei Haftung.

### **Condizioni di Utilizzo**

I sistemi di telecamere e monitor costituiscono un prezioso ausilio alla guida, ma il conducente deve comunque assicurarsi di prendere tutte le normali precauzioni quando esegue una manovra. Né Brigade né il suo distributore saranno responsabili per eventuali danni di qualsiasi natura causati dall'utilizzo o dal mancato utilizzo del prodotto.

### **Aviso legal**

Aunque los sistemas de cámaras con pantalla constituyen una valiosa ayuda, no eximen al conductor de tomar todas las precauciones normales al hacer una maniobra. Brigade y sus distribuidores comerciales no se responsabilizan de cualquier daño derivado del uso o de un mal funcionamiento del producto.

Specifications subject to change. Sous réserve de modifications techniques. Änderungen an den technischen Daten vorbehalten. Specifiche soggette a variazioni. Las especificaciones están sujetas a cambios. Wijzigingen in specificaties voorbehouden. As especificações estão sujeitas a alterações. Спецификация может изменяться.

### **Declinación de responsabilidad**

Os sistemas de monitoria da câmara são uma ajuda incalculável ao motorista, mas não dispensam o motorista de tomar todas as precauções normais ao realizar uma manobra. Nenhuma responsabilidade decorrente do uso ou falha do produto pode de forma alguma ser atribuída ao Brigade ou ao distribuidor.

### **Verwerping**

De camera-monitorsystemen zijn een waardevolle hulp voor de bestuurder, maar ontheffen hem echter niet van de verplichting om het voertuig zorgvuldig te manoeuvreren. Brigade en zijn distributeurs zijn niet aansprakelijk voor schade door gebruik of het niet functioneren van het product.

### **Отказ от обязательств**

Системы камерного слежения являются крайне полезным средством помощи водителю, но не освобождают водителя от обязанности соблюдения всех необходимых мер предосторожности при совершении маневра. На компанию Brigade или распространителя продукции не налагается никакая ответственность, возникающая по причине использования или неисправности данного продукта.

Serial No:

Part No:



[www.brigade-electronics.com](http://www.brigade-electronics.com)

